

iM 18

Spiral kneading machine for pizza, pastry and bakery



EXTERNAL CONSTRUCTION

- Structure in powder painted stainless steel.
- Spiral, basin, dough-breaker and safety grille in stainless steel.
- Thick frame to avoid vibrations in every working phase.
- Push-button panel on the right side.
- Machinery on rotating wheels.

INTERNAL CONSTRUCTION

- Motorization with bath oil motoreducer.
- Chain drive.
- Rotating transmission parts are assembled on self lubricating ball bearings.
- Electrical equipment with low-voltage auxiliary circuit.
- Safety device for grille.

OPERATION

- Dough homogeneity and oxygenation by the combined rotating movement of the utensil and basin.
- The shape of the spiral assures a low and constant temperature of dough during the working.
- Possibility to mix maximum 18 Kg in few minutes.

STANDARD EQUIPMENT

- Spiral
- Basin
- Dough-breaker
- Rotating wheels
- Timer



MORETTI FORNI S.P.A.

www.morettiforni.com

info@morettiforni.com

Via A.Meucci, 4 - 61037 Mondolfo (PU) ITALIA

Tel. +39.0721.96161 - Fax +39.0721.9616299



iM 18

TOP VIEW

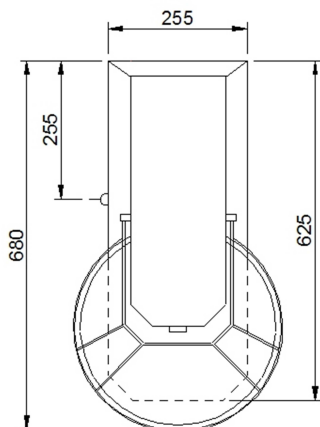

REAR VIEW

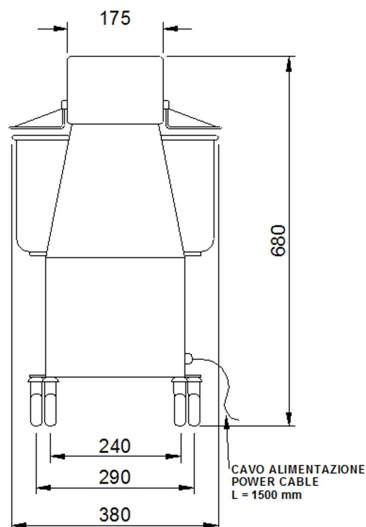

RIGHT SIDE VIEW

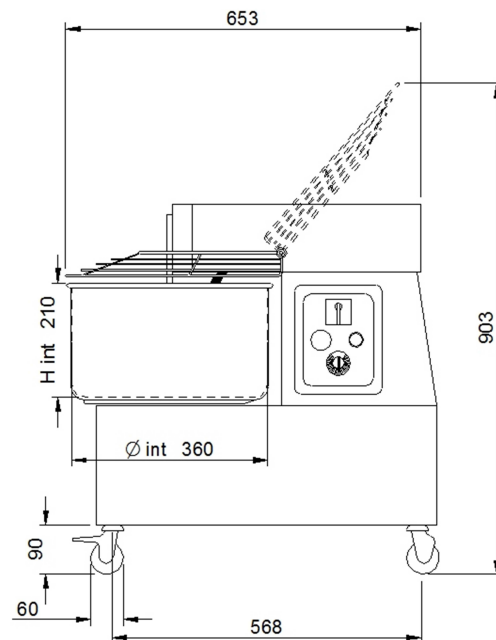

Note: The dimensions indicated in the views are in millimeters

SPECIFICATIONS

Spiral kneading with firm head, ideal for small spaces with rotating wheels. To the construction are used high quality and robustness materials. Thanks to the particular shape of spiral and to the rotating movement of the utensil combined with that of the basin, the spiral kneading, gives possibility to mix in few minutes 18 Kg dough, and assures very good homogeneity and oxygenation. The model assures constant temperature of the dough from beginning to end working, so eliminate the danger of incidental overheating. The transmission system is particularly silent because all parts are assembled on watertight ball bearings with bath oil motoreducer, free maintenance. The machinery is provided of indispensable safety devices .

TECHNICAL FEATURES

DIMENSIONS

External height	680 mm
External depth	680 mm
External width	380 mm
Weight	65 kg

SHIPMENT INFORMATION

Packed machinery:	
Max height	755 mm
Max depth	750 mm
Max width	480 mm
Weight	(65+5)kg

FEEDING AND POWER

<i>Standard feeding</i>	
A.C. V400 3 Power 0.75 kW	
Frequency	50 Hz

BASIN CAPACITY

Capacity (dough)	18 kg
Capacity (volume)	20 lt
Basin internal diameter	360 mm
Basin internal height	210 mm
Spiral diameter	18 mm

<i>Feeding on request</i>	
A.C. V230 3 Power 0.75 kW	
A.C. V230 1N Power 0.88 kW	
Frequency	50 Hz

On request frequency 60 Hz